

Polyamide Hexagonal Insulators

Polyamide Hexagonal standoff insulators available in both Metric & UNC Threads & in variety of heights & inserts, Male-Female & Male-Male Inserts combination.

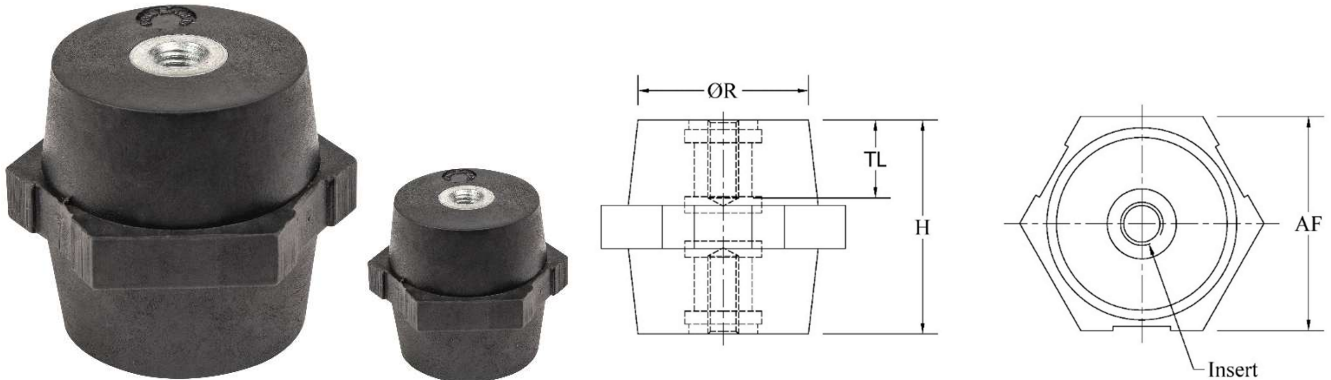

- Glow Wire Test - 960 °C
- Self-Extinguishing, UL 94 V0 Rated
- Halogen Free
- Operating Temperature range from (-) 40°C to 130°C.

Part No	Dimensions				Nominal Voltage (AC/DC)
	Height (H)	AF	Ø R	TL	
(Insert)	mm	mm	mm	mm	
PH 420 (M4)-V0	20	18	15	5	1100/1500
PH 620 (M6)-V0	20	18	16	5	1100/1500
PH 6(7)20(M6)-V0	20	18	16	7	1100/1500
PH 525 (M5)-V0	25	20	16	7	1400/1900
PH 625 (M6)-V0	25	20	16	7	1400/1900
PH 630 (M6)-V0	30	30	26	9	1600/2200
PH 830 (M8)-V0	30	30	26	9	1600/2200
PH 635(M6)-V0	35	40	34	12	1900/2600
PH 835 (M8)-V0	35	40	34	12	1900/2600
PH1035 (M10)-V0	35	40	34	12	1900/2600
PH 640 (M6)-V0	40	45	40	12	2200/3000
PH 840 (M8)-V0	40	45	40	12	2200/3000
PH1040 (M10)-V0	40	45	40	12	2200/3000
PH1240(M12)-V0	40	45	40	12	2200/3000
PH645L(M6)-V0	45	41	34	12	2500/3500
PH845L(M8)-V0	45	41	34	12	2500/3500
PH 845 (M8)-V0	45	50	40	12	2500/3500
PH1045 (M10)-V0	45	50	40	12	2500/3500
PH 650 (M6)-V0	50	50	40	17	2800/3900
PH 850 (M8)-V0	50	50	40	17	2800/3900
PH1050 (M10)-V0	50	50	40	17	2800/3900



PH 860 (M8)-V0	60	54	45	17	3300/4600
PH1060 (M10)-V0	60	54	45	17	3300/4600
PH1260 (M12)-V0	60	54	45	17	3300/4600
PH1270 (M12)-V0	70	65	50	21	3900/5400
PH1670 (M16)-V0	70	65	50	21	3900/5400
PH-1075(M10)-V0	75	65	50	21	4200/5800
PH1275 (M12)-V0	75	65	50	21	4200/5800
PH1675 (M16)-V0	75	65	50	21	4200/5800
PH1280 (M12)-V0	80	65	50	25	4500/6300
PH1680 (M16)-V0	80	65	50	25	4500/6300
PH12100 (M12)-V0	100	65	50	25	5600/7800
PH16100 (M16)-V0	100	65	50	25	5600/7800

- All Dimensions are in mm only.
- Tolerance is applicable as per DIN Standard 2768.

-----Global Commitment

www.powermatindia.com



Mail us : powermat@powermatindia.com