

## PATM Busbar Supports

**PATM Busbar Support offers versatile solution for higher short circuit rating and can hold Single Run to Multiple Runs of 6.0mm, 10mm & 12mm Busbars.**

- Suitable for Solar Panel Application, 800 Volt AC systems
- Material: Glass Reinforced Polyamide 6.6
- Flammability: UL 94 V-0
- Glow Wire: 960 °C
- Creepage Distance - > 50.0 mm
- Equipment Voltage Ue: 1000 V AC, 1500 V DC
- Insulation Voltage Ui: 1000 V AC, 1500 V DC
- Impulse Voltage Uimp: 12 kV
- Strong Support for higher current rating
- Support can hold one, two, three & four conductors
- Minimize the Panel heights.

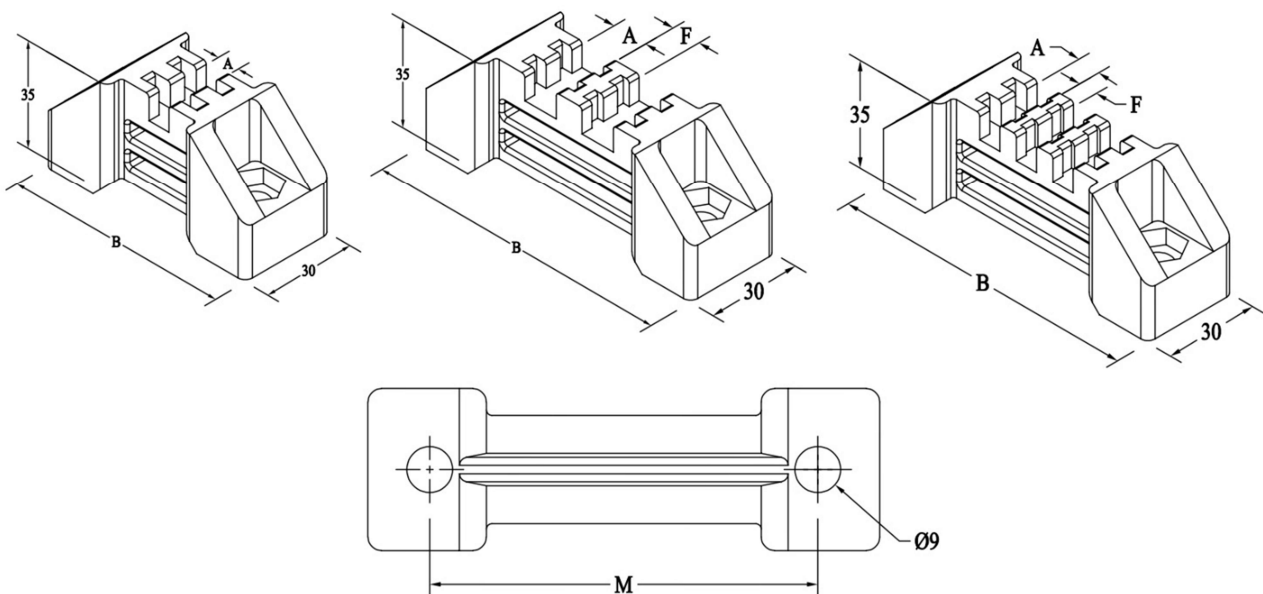

Busbar Size	PEPL Code	Dimension, in mm			
		A	F	B	M
6mm x 1R	PATM 106	7	-	70	47
10MM x 1R	PATM 110	11	-	70	47
12mm x 1R	PATM 112	13.7	-	70	47
6mm x 2R	PATM 206	7	5.8	95	72
10mm x 2R	PATM 210	11	9.0	95	72
12mm x 2R	PATM 212	13.7	11.0	95	72
6mm x 3R	PATM 306	7	5.8	95	72
10mm x 3R	PATM 310	11	9.0	125	100
12mm x 3R	PATM 312	13.7	5.8	125	100

- All Dimensions are in mm only.
- Tolerance is applicable as per DIN Standard 2768.

-----*Global Commitment*

[www.powermatindia.com](http://www.powermatindia.com)



Mail us : [powermat@powermatindia.com](mailto:powermat@powermatindia.com)